

FDS TSF pánt nélküli felnyíló vasalat

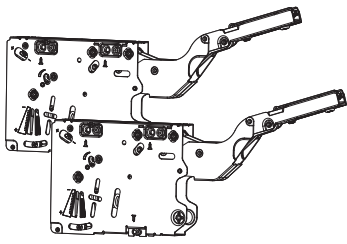

1 pár emelőkar

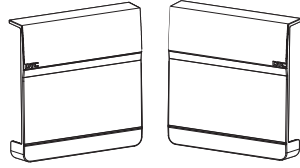

1 pár takarósapka

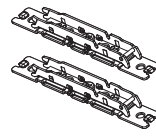

1 pár előlaprögztítő
fa ajtóhoz



csavarok

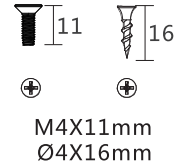

Pozicionáló stiftek helyzete

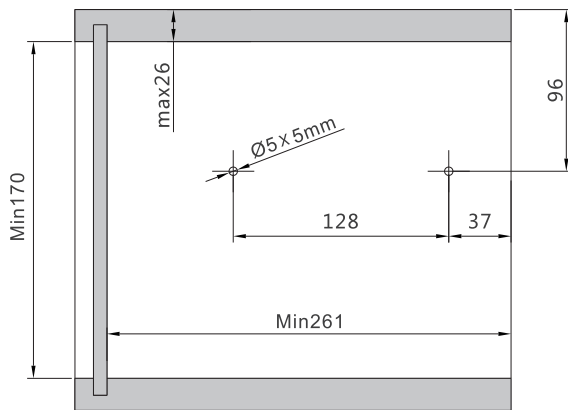

Jobbos és balos oldallapon a csavarozási pontok helyzete

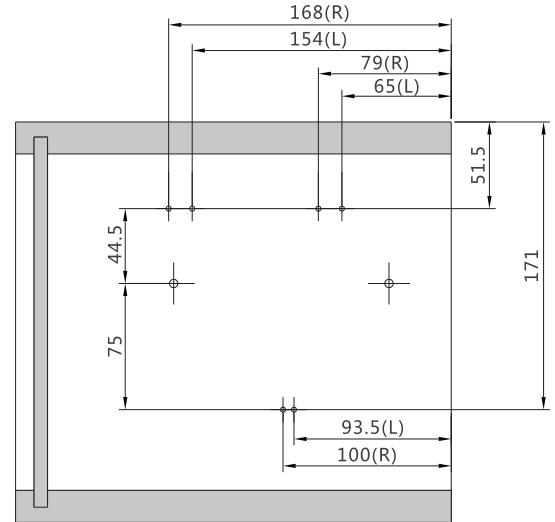

korpusz magasság KH (mm)	ajtó súlya (kg)*		
250	3,0-10,0	-	-
300	2,5-8,3	-	-
350	2,1-7,1	4,3-14,0	-
400	1,9-6,3	3,8-12,3	8,0-22,5
450	1,7-5,6	3,3-10,9	7,1-20,0
500	1,5-5,0	3,0-9,8	6,4-18,0
550	-	-	5,8-16,4
600	-	-	5,3-15,0
650	-	-	4,9-13,9
700	-	-	4,6-12,9
cikkszám	10003337100	10003337120	10003337140

*Ajtó súlya (kg)= ajtólap súlya + 2x fogantyú súlya (kg)

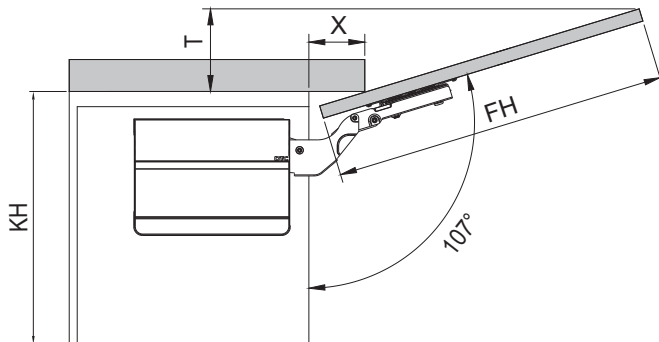

$$T = FH \times 0,29 - 15 + \text{ajtólap vastagság (mm)}$$

Ajtólap vastagság (mm)	18	19	20
X (mm)	64	58	55

KH = korpusz magasság (mm)

Előlaprögztítő helyzete

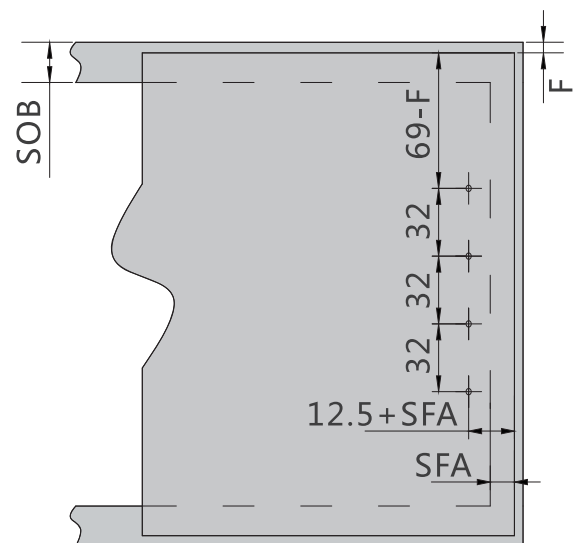

SOB = tetőlap vastagság (mm)

SFA = ajtólap ráütődése az oldallapra (mm)

F = fuga (mm)

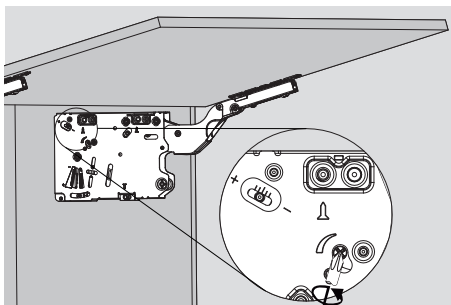
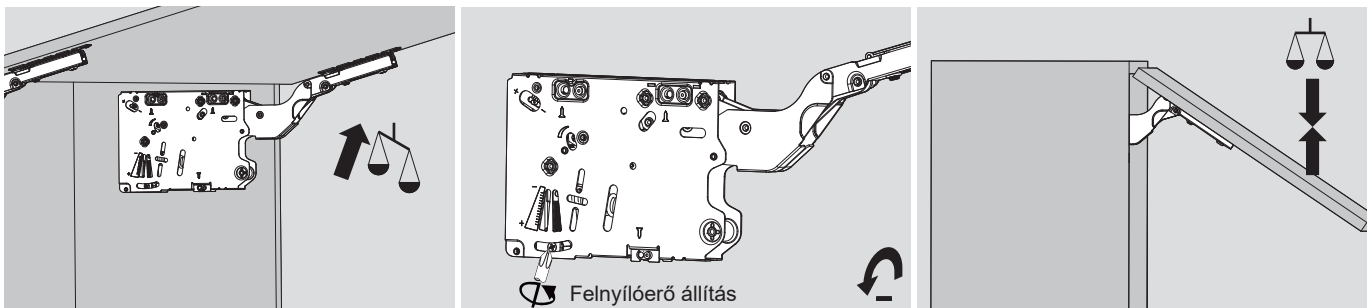
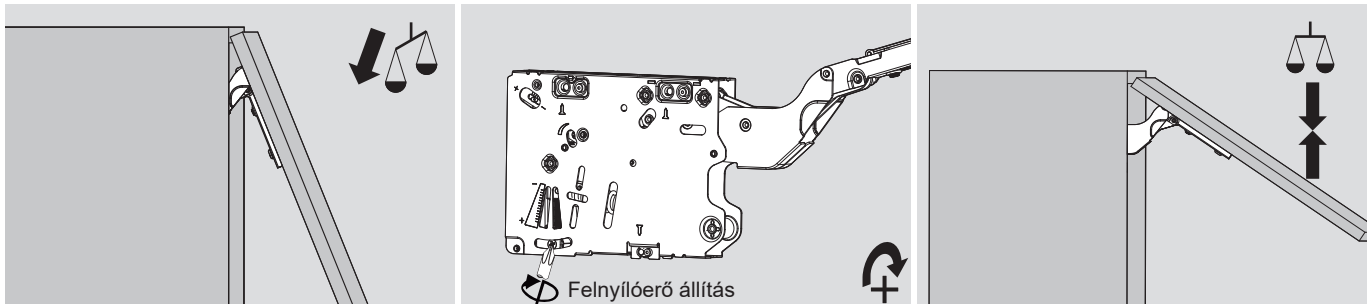
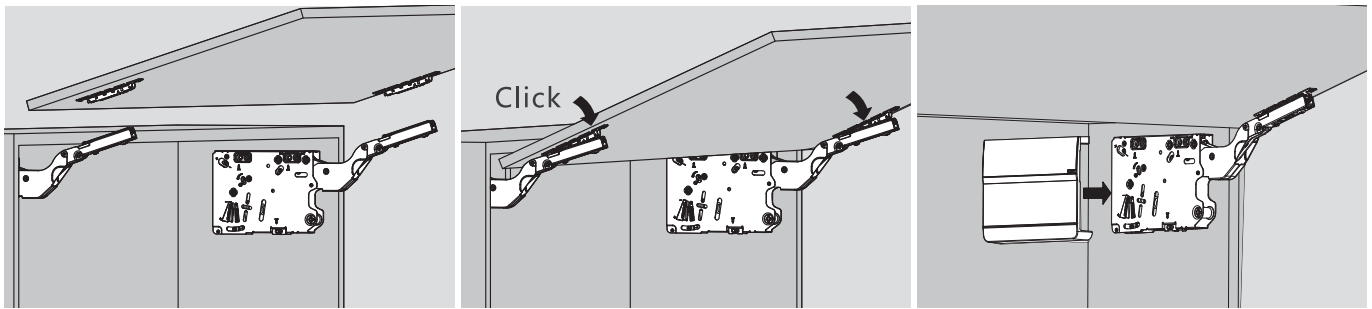
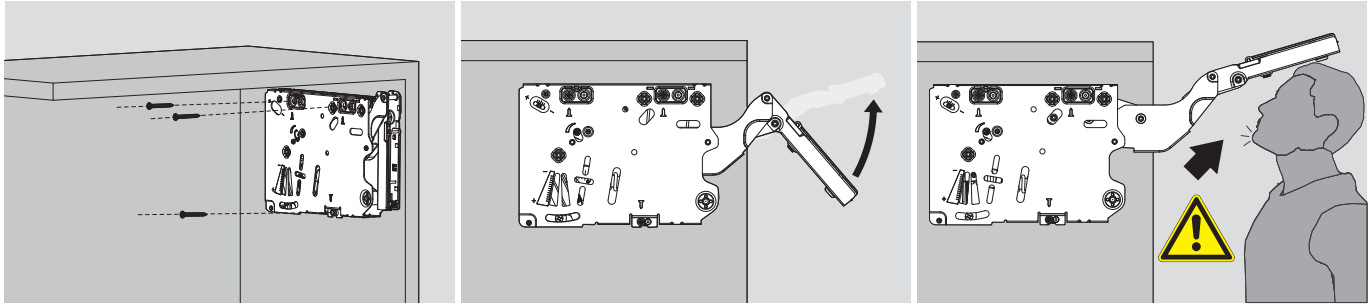

“+” csillapítás erősítése
“-” csillapítás gyengítése

